

Forno Fusorio Ribaltabile ROL 400

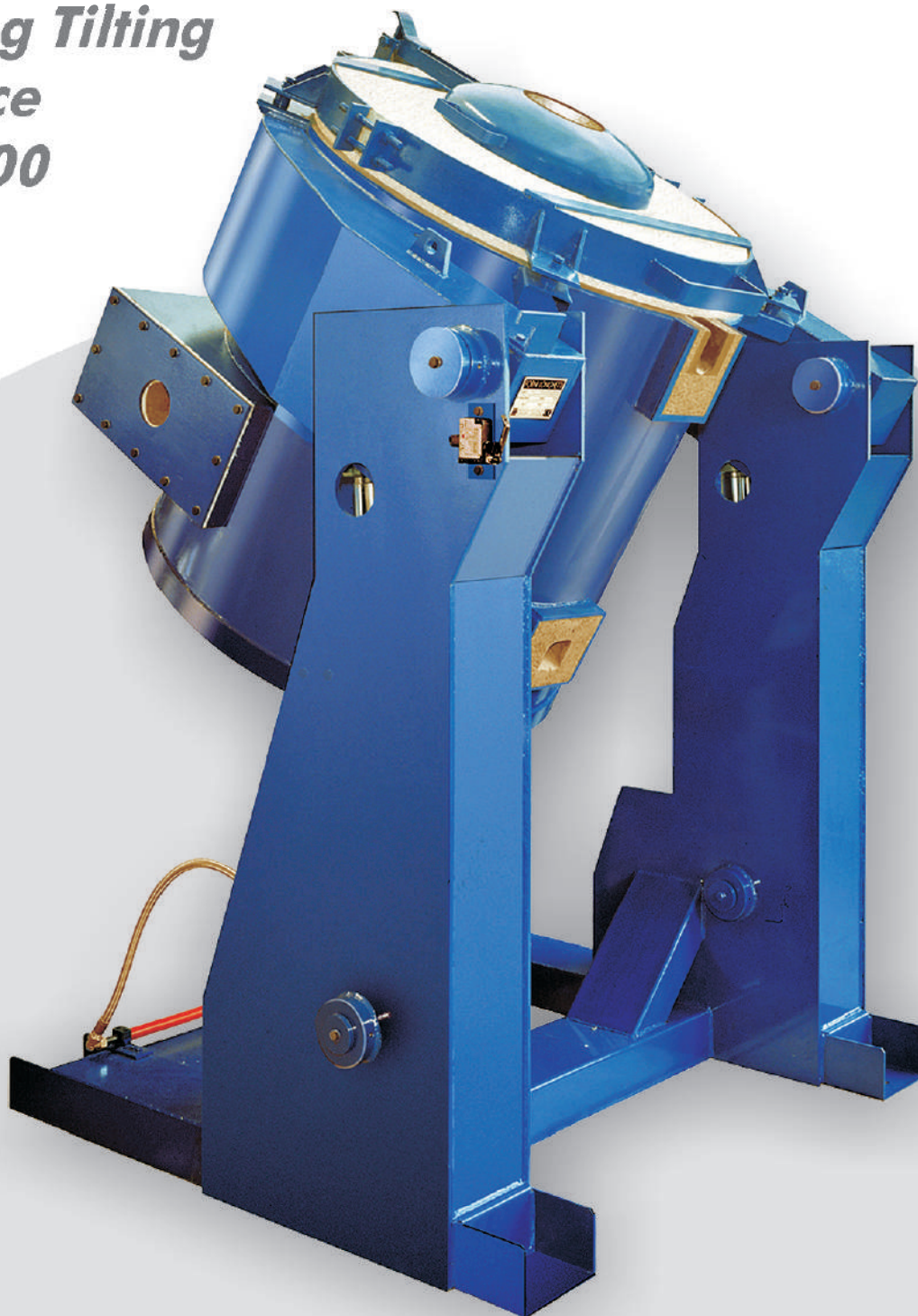

*Melting Tilting
Furnace
ROL 400*



Per la fusione di leghe e metalli preziosi e non ferrosi a temperature elevate (sino a 1350 °C) in pani, lingotti o gocce.

Questi forni, sono equipaggiati con sistemi di ribaltamento idraulico in asse rispetto al becco di colata con controllo remoto ad inverter, bruciatore automatico anche con sistema di combustione gas-ossigeno libero.

For the melting of precious metals and not ferrous alloys with high melting point (till up 1350 °C) in ingot, moulds or drops.

These ovens, are equipped with safety tilting hydraulic system on the line of the pouring channel under inverter remote control, automatic burner also available with system feeded with pure oxygen and gas.

Forno Fusorio Ribaltabile ROL 400

*Melting Tilting
Furnace
ROL 400*

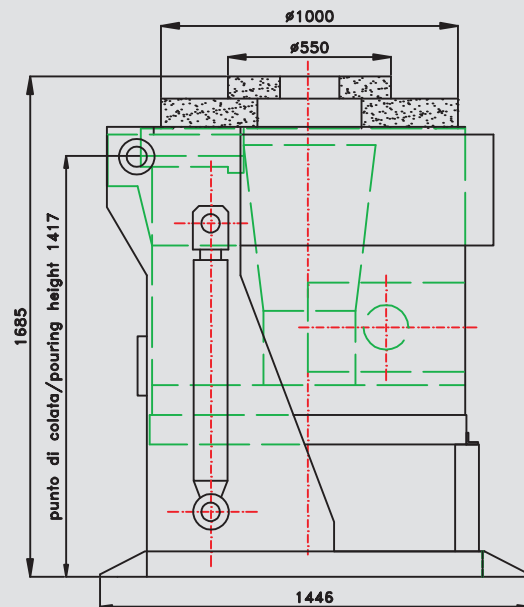

INGOMBRI BRUCIATORE IN FUNZIONE DI MODELLO E COMBUSTIBILE
BURNER DIMENSIONS IN FUNCTION OF MODEL AND FEEDING

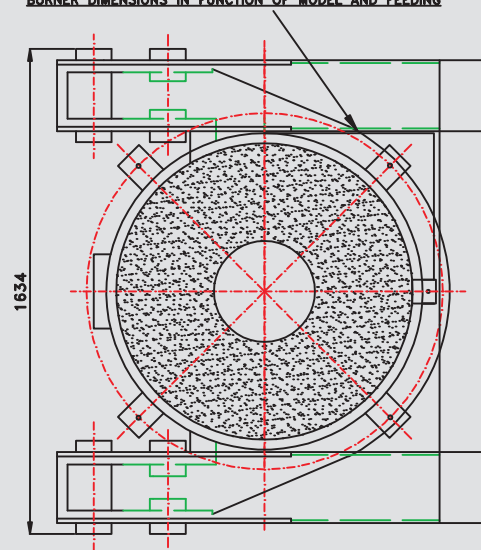
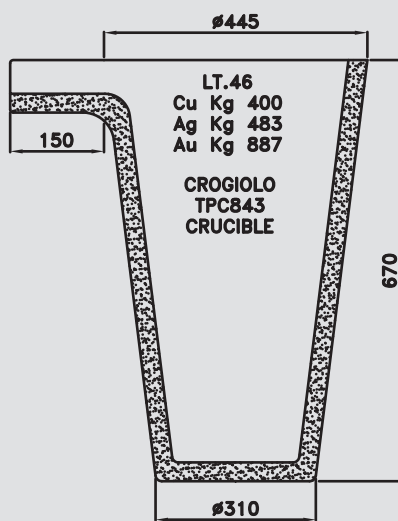

Caratteristiche principali

Peso complessivo: kg. 3150
Potenza elettrica: KW 3,2
Crogiolo max: TPC843 = 400Kg.Cu = 46lt.(*)
Potenzialità termica: max 300.000 Kcal/h
Consumi Ch4: max 35,3 Nmc/h
Consumi GPL: max 25 Kg/h
Bruciatore: automatico a gas (**)
Standard applicati: CE

Main features

Total weight: kgs. 3150
Electric power: KW 3,2
Max crucible: TPC843 = 400Kgs Cu = 46 lts.(*)
Max thermal power: 300.000 Kcal/h
Ch4 consumption: max 35,3 Nmc/h
LPG consumption: max 25 Kgs/h
Burner: automatical working with gas (**)
Standards: CE

(*) Altre capacità su richiesta

(**) Su richiesta bruciatori a gasolio e con sistema ossi-gas

(*) Other capacities on demand

(**) Diesel oil and oxy-gas burners on demand



F.I.M.O. snc di Reina M. & Longhetti S.G. - Via L. Biagi, 55 - 20099 Sesto San Giovanni - Mi - Italy
Telefono +39 02 2485793 - Fax +39 02 24416852 - www.fornilonghetti.it - info@fornilonghetti.it