

# Forno Fusorio Ribaltabile ROL 100/120/150



## *Melting Tilting Furnaces ROL 100/120/150*



Per la fusione di leghe e metalli preziosi e non ferrosi a temperature elevate (sino a 1350 °C) in piani, lingotti o gocce.

Questi forni, grazie al pratico e sicuro sistema di ribaltamento idraulico in asse rispetto al becco di colata con controllo remoto ad inverter, trovano impiego nel **ciclo di recupero dei metalli preziosi** (colata nelle staffe coniche ME) e nei processi di **granigliatura preaffinazione** (con il nostro sistema di gocciolatura VSC).

Per i migliori risultati di recupero ricordiamo l'utilizzo dei nostri fondenti **FONDOR**, **OXIDOR** e il rinnovato **FONDOR LL 150632**.

For the melting of precious metals and not ferrous alloys with high melting point (till up 1350 °C) in ingot moulds or drops.

These ovens, by mean of their safety tilting hydraulic system on the line of the pouring channel under remote inverter control, are often used in the **precious metals recovery process** (casting in our cast iron cones ME) and for the **production of grains for the chemical refining system** (by mean of our graining system VSC).

To obtain the best efficiency of recovery we recommend the utilization of our fluxes **FONDOR**®, **OXIDOR**® and the new compound **FONDOR LL 150632**®.

# Forno Fusorio Ribaltabile ROL 100/120/150

## Melting Tilting Furnaces ROL 100/120/150

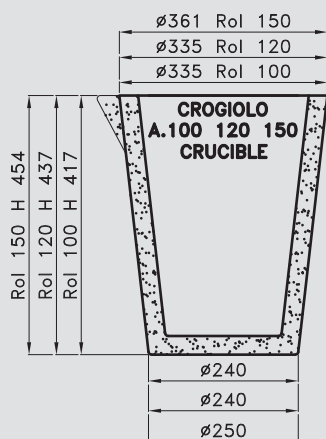

Capacità Crogioli - Crucibles Capacities				
Crogiolo - Crucible	Lt.	Cu	Ag	Au 24 KT
A.100	13	kg 100	Kg 135	Kg 251
A.120	14	Kg 120	Kg 147	Kg 270
A.150	18	Kg 150	Kg 189	Kg 347

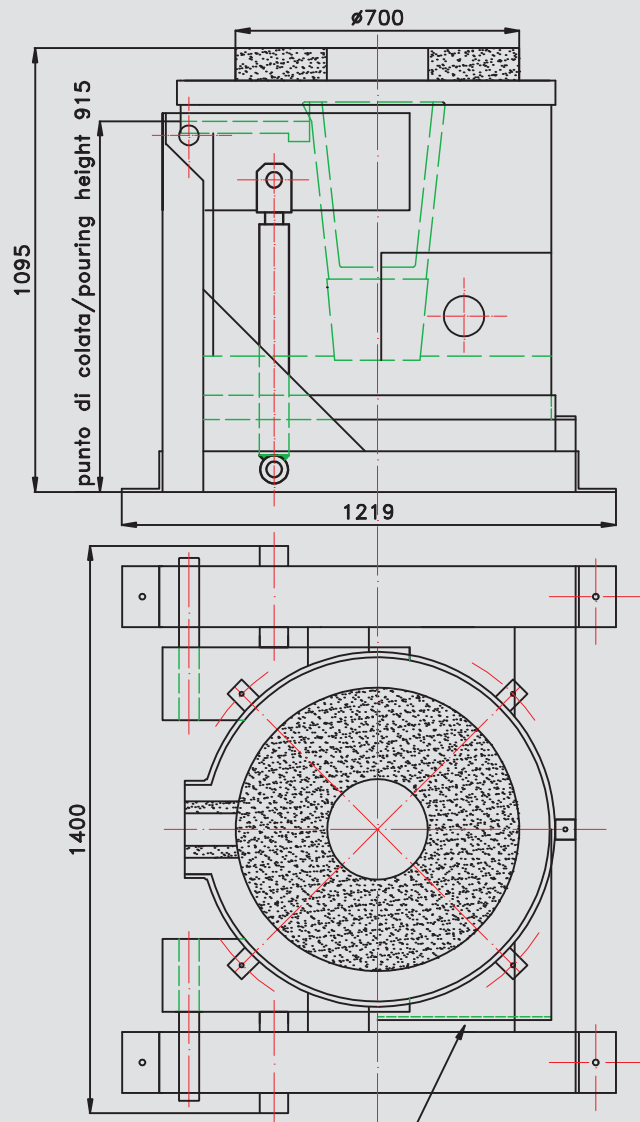

INGOMBRI BRUCIATORE IN FUNZIONE DI MODELLO E COMBUSTIBILE  
BURNER DIMENSIONS IN FUNCTION OF MODEL AND FEEDING

### Caratteristiche principali

Peso complessivo: kg. 1150  
Potenza elettrica: KW 1,2  
Crogiolo max: A.150 = 150Kg.Cu = 18lt. (\*)  
Potenzialità termica: max 150.000 Kcal/h  
Consumi CH4: max 17,7 Nmc/h  
Consumi GPL: max 12,5 Kg/h  
Bruciatore: automatico a gas (\*\*)  
Standard applicati: CE

### Main features

Total weight: kgs. 1150  
Electric power: KW 1,2  
Max crucible: A.150 = 15Kgs.Cu = 18 lts (\*)  
Max thermal power: 150.000 Kcal/h  
CH4 consumption: max 17,7 Nmc/h  
LPG consumption: max 12,5 Kgs/h  
Burner: automatical working with gas (\*\*)  
Standards: CE

(\*) Altre capacità su richiesta  
(\*\*) Su richiesta bruciatori a gasolio

(\*) Other capacities on demand  
(\*\*) Diesel oil burner on demand

