

Forno Fusorio COMPACT 6 AC / AS



Melting

Furnace

COMPACT 6 AC /AS



COMPACT 6 AS



COMPACT 6 AC

Per la fusione ad alte temperature di leghe metalli preziosi e recuperi.

Costi ridotti ed economia di esercizio, massima silenziosità e grande affidabilità.

Assenza di alimentazione elettrica per il modello AC.

For the high temperature melting of precious metals alloys and fill dust.

Reduced cost and energetic saving, low noise and large reliability.

Absence of electric power supply for the AC model.

Forno Fusorio COMPACT 6 AC / AS

Melting Furnace COMPACT 6 AC / AS

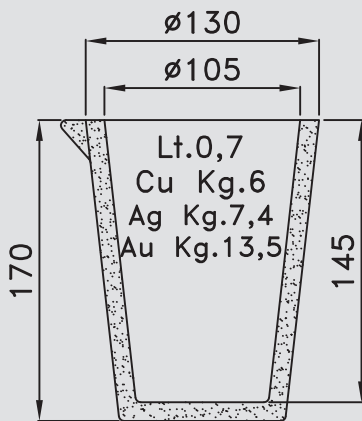

CROGIOLO A.6
CRUCIBLE A.6

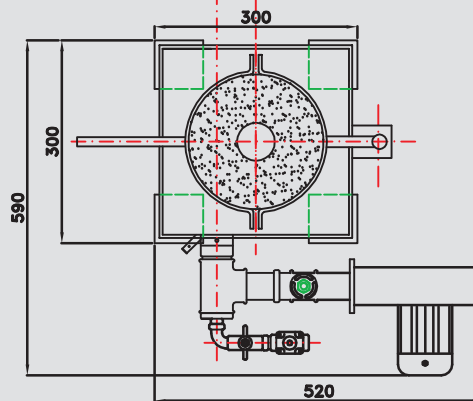
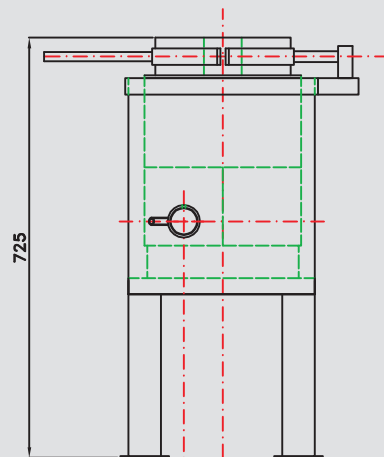

COMPACT 6 AS

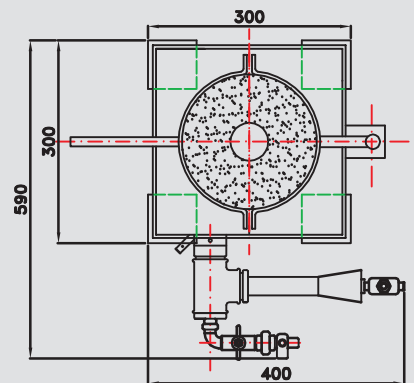

COMPACT 6 AC

Caratteristiche principali

Peso complessivo: Kg. 45 (40 mod. AC)
Potenza elettrica: KW 0,08 (0 mod. AC)
Capacità crogiolo: A.6
Potenzialità termica: max 25.000 Kcal/h
Consumi CH₄: max 2,94 Nmc/h
Consumi GPL: max 2 Kg/h
Standard applicati: CE

Main features

Total weight: Kgs. 45 (40 for mod. AC)
Electric power: KW 0,08 (0 for mod. AC)
Crucible capacity: A.6
Max thermal power: 25.000 Kcal/h
CH₄ consumption: max 2,94 Nmc/h
LPG consumption: max 2 Kgs/h
Standards: CE

